



**ENVASES SANZ BELDA, S.L.**

Tel.: 34 96 236 02 32 - calidad@envasesanzbelda.es - www.envasesanzbelda.es  
Pol. Ind. San José. Avda, Valencia, parc. 7 - Apdo. de Correos 46 - 46812 Aielo de Malferit. Valencia. (España)



Technical comercial data ref.

**M.N-0.80 T.M-0.80**

Serie MASTER NOVA – Versión 26-07-2023

## TECHNICAL DATA:

Material: PP copolymer of first quality, suitable for contact with food according to current regulations.

Colours: White standard. Consult for other colours.

Useful Volume: 0.8 litres

Volume to the edge: 0.9 litres

Weight of the bucket: 47 g. approx.

Weight of the lid: 15 g. approx.

Total Weight: 62 g. approx.

Design surface photographic finish: 75 x 335 mm (height x perimeter)



## MEASUREMENTS:

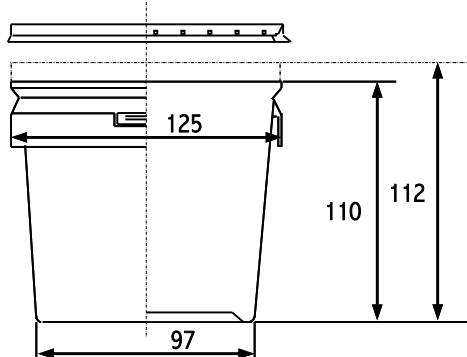

Measurements in millimetres

## GROUPING OF TRANSPORT:

Tubs: 6500 tubs per pallet  
250 tubs per box, this serves as a packaging of transportation

Box dimension: 370 x 250 x 895

Pallet dimensions: 1250 x 1000 x 2000 (see drawing)

Lids: 500 lids per box, this serves as a packaging of transportation

Box dimension: 210 x 490 x 630

